



ASSEMBLY MANUAL

TRAP BEAM 24 & 18 MHz

248A

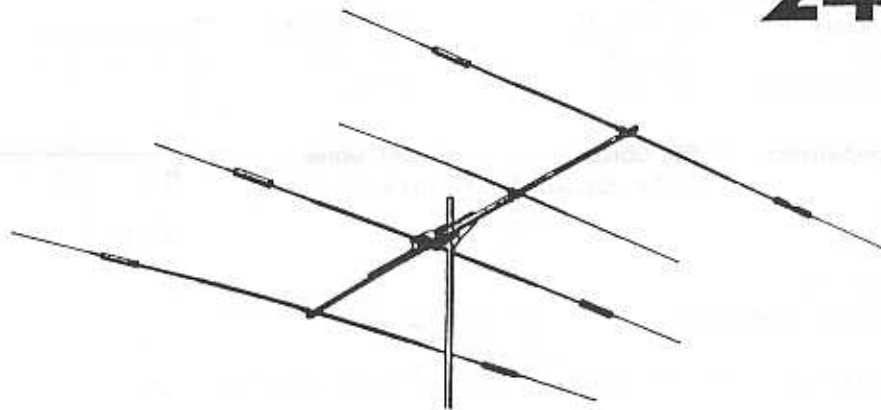

Figure 1.

FSAD

1ST EDITION 1989-7

Creative Design Co., Ltd.
Asano-cho 4-8, Kawasaki-ku,
Kawasaki, 210 Japan

1. FEATURES AND DESCRIPTIONS

As shown in the Figure 1, the model 248A is a 4-element 2 band Yagi beam antenna for both 24MHz and 18MHz bands. The optimum communication distance is 1000 to 2000km or more and coverage frequencies are from 24.9 to 25.00MHz and from 18.07 to 18.17MHz. Band switching is by means of CD's exclusive high Q trap designed to derive an optimum frequency efficient and high power withstand with low loss RF energy. In general, element spacing is very important factor to obtain full performance in Yagi type beam antenna. Those for 24MHz are full sized, wide space 4 element while 18MHz are 85% reduced size, medium space 4 element antenna. The most critical part of this antenna, trap is designed for the optimum factor for each element. Only the finest material are used for the construction of this antenna.

1.2 SPECIFICATIONS

Frequency:	18MHz	24MHz
Number of Element:	3	4
Forward Gain:	7 - 9 dB	8 - 10 dB
F/B Ratio	20 dB	30 dB
Power Capability:	1/2 kW	1/3 kW
(CW/PEP)		
Input Impedance:	50 Ohms	50 Ohms
VSWR:	- As Shown in Figure 2 -	
Element Length:	7.46 m	
Boom Length:	4.60 m	
Mast Diameter:	49 - 61 mm	
Wind Survival Rating:	35 m/s = 226 km/h	
Weight:	14 Kg.	
Recommended Rotator:	CD RC5-1 type of equivalents	

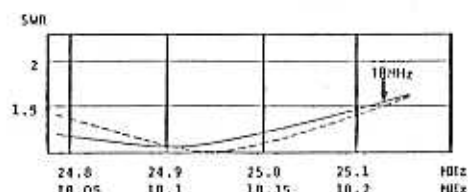

Figure 2. VSWR, 248A. 18m/h

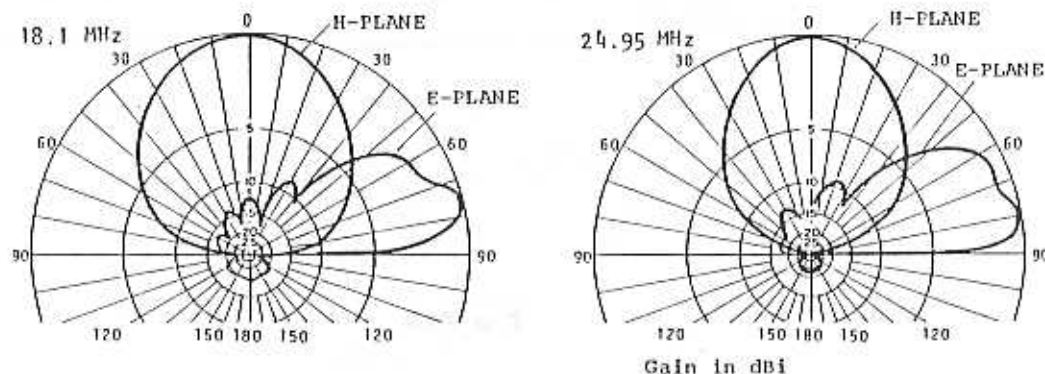

Figure 3. Elevation and Azimuth Patterns.

1.3 EQUIPMENTS NOT SUPPLIED, AND NECESSARY TOOLS

Refer to the PARTS LIST, for a complete breakdown of parts contained in this antenna after unpacking. The model 248A antenna is supplied complete and corresponds to the drawings contained in the parts list in the Section 4. in this manual. Refer to the IM7601 in later page also for required tools for assembly and installation for this antenna.

2. ASSEMBLY

The overall construction of this model 248A is shown in Figure 7. These are the diagrams that is viewed from the two directions respectively, one is from top while another is from the side. This antenna consists of boom, driven element (radiator), parasitic element and balun transformer model CB2F. Key instructions for assembling this antenna are as shown in Figure 5 - 7 and all the parts for assembling is supplied complete and corresponds to the drawings and contained in the parts list in the Section 4. in this manual. Assembling of this antenna is accordance with the following steps is recommendable.

- () 1. Boom Assembly, Mast Bracket and Stub Rod Mounting Figure 5.
- () 2. Driven Element, Parasitic Element Assembly Figure 6.
- () 3. Mounding each Element on the Boom Figure 6.

FRONT

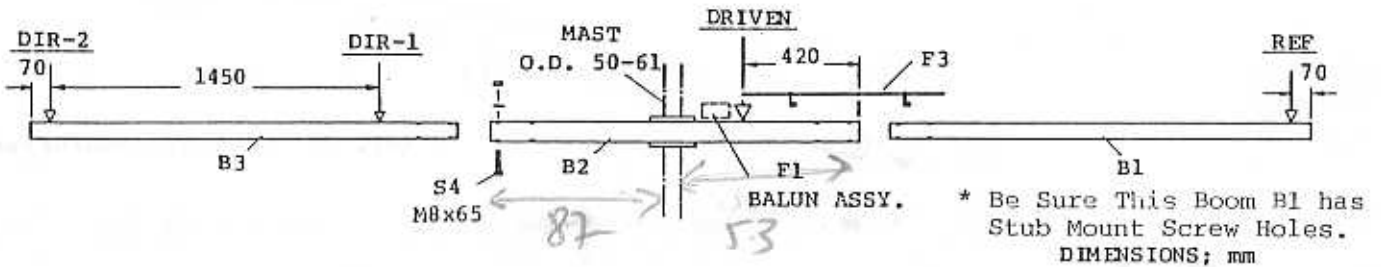
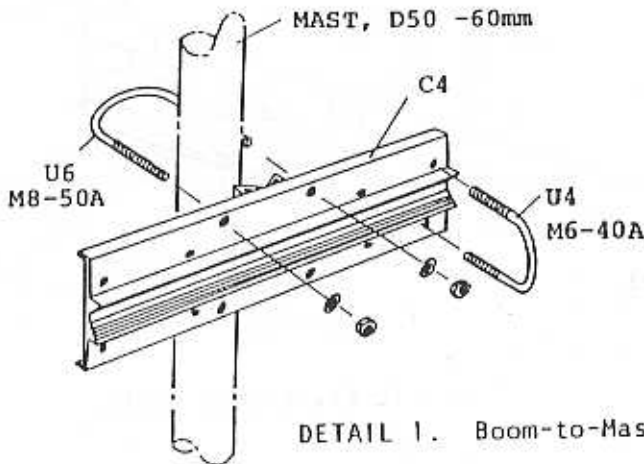

Figure 5. Boom Assembly, 214A.

Mast Bracket Assembly

Priorly assemble antenna mount bracket (C4) to the boom. Be sure that the boom is mounted at the right angle.



DETAIL 1. Boom-to-Mast Clamp.

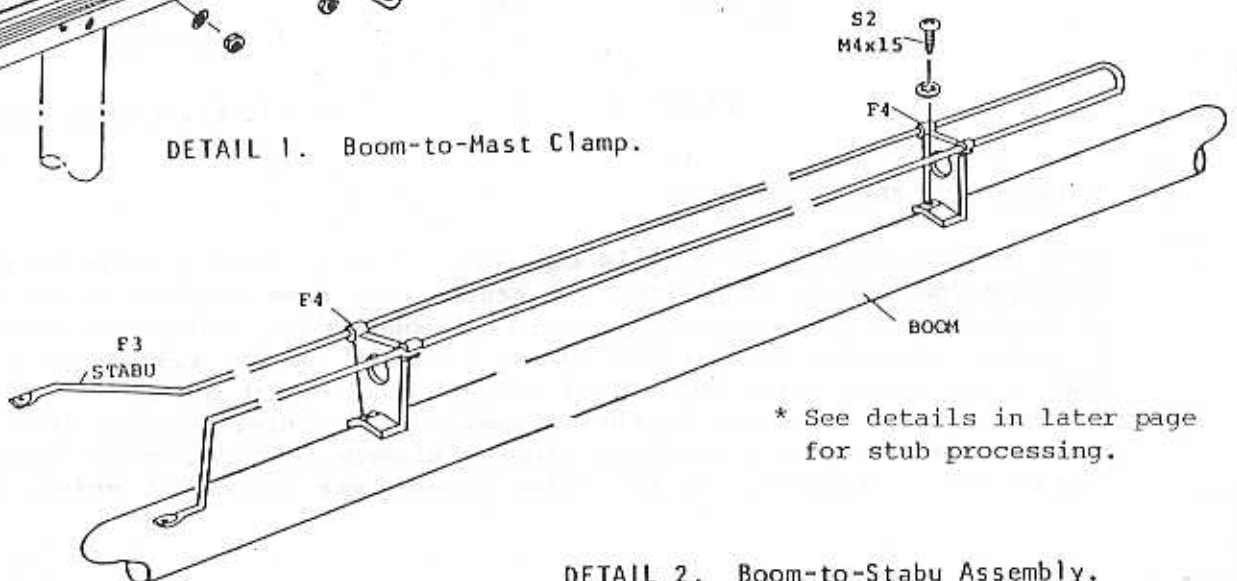

* See details in later page for stub processing.

DETAIL 2. Boom-to-Stub Assembly.

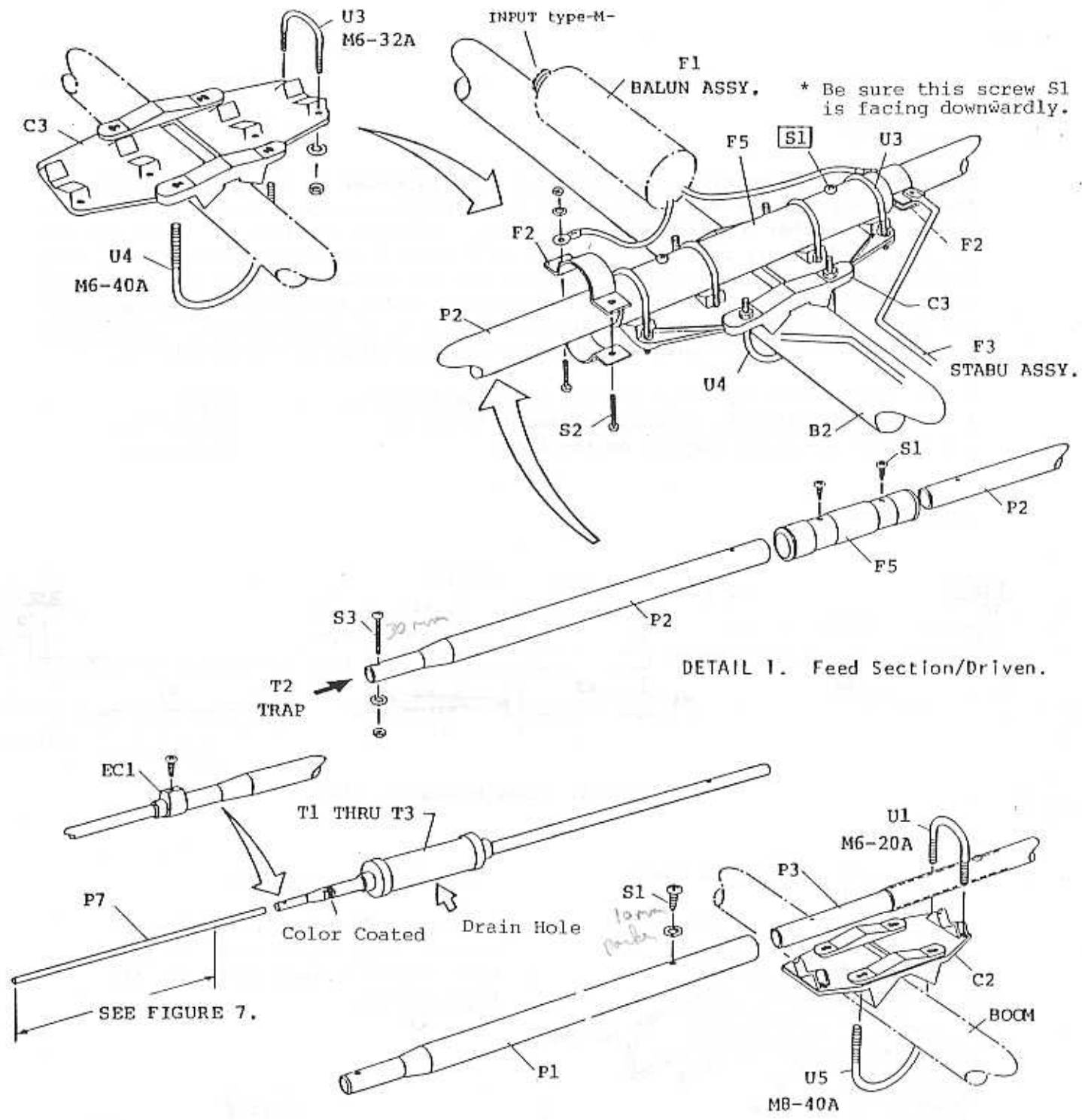

Figure 6. Driven and Parasitic Element Assembly.

3. OPERATION AND INSPECTION

After installation of antenna is completed, connect feeder cable to it, start checking VSWR before operation. If assembly is done completely and there is no misassembly, VSWR value and resonant frequency characteristic would become a similar character to the VSWR chart indicated in the 1.3, however if this VSWR value excess more than 2.1:1 and resonant point is out of the bands, think something is wrong in the assembling procedure. Check those contact points such as feeding section, tipping element section, cable-to-connector contact etc. Normally, if the balun transformer is out of order, the VSWR

value indicates more than 4 - 8:1 over the entire bands. Also the antenna is mounted in such a surroundings area where closed to metal object or is stacked with another antenna, VSWR value will be effected accordingly (If a 3 - 11 element on 144MHz band antenna is stacked mounting within the 1m close, resonant frequency especially 24MHz may shift from its optimum point). If you wants to shift resonant frequency, some adjustment is required by changing the insertion between P2 tubings and T2 trap for 18MHz band while between T2 and tipping tube P7. 10mm of the insertion adjustment of tip element may change approx. 45KHz of resonant frequency shift. Adjust resonant frequency by or either increasing or shortening the tip element length.

4. EQUIPMENT SUPPLIED

The model 248A antenna is supplied complete and corresponding to the drawings contained in the manual. Refer to the PARTS LIST, for a complete breakdown of parts after unpacking. The following listed equipment are required for assembling model 248A. The model 248A is supplied complete and corresponds to the drawings contained in the following parts list:

PARTS LIST

ITEM	DESCRIPTIONS		Q'TY
B1	TUBE,	Boom $\phi 46 \times 1800$	Alum. 1
B2	TUBE,	Boom $\phi 50 \times 1400$	Alum. 1
B3	TUBE,	Boom $\phi 46 \times 1800$	Alum. 1
P1	TUBE,	Element $\phi 25 \times 1900$	Alum. 4
P2	TUBE,	Element $\phi 25 \times 1900$ - <i>blen</i>	Alum. 2
P3	TUBE,	Element $\phi 22 \times 500$	Alum. 2
P4	TUBE,	Element $\phi 20 \times 1280$	Alum. 1
P5	TUBE,	Element $\phi 17 \times 1200$	Alum. 2
P6	TUBE,	Element $\phi 10 \times 900$	Alum. 2
P7	TUBE,	Element $\phi 10 \times 460$	Alum. 6
T1	TRAP ASSY.	Element Ref. (Black)	Alum. 2
T2	TRAP ASSY.	Element Driven (None)	Alum. 2
T3	TRAP ASSY.	Element Dir. (Orange)	Alum. 2
C1	CAST CLAMP	Element MC-70	Alum. 1
C2	CAST CLAMP	Element MC-90	Alum. 2
C3	CAST CLAMP	Element MC-110	Alum. 1
C4	CAST CLAMP	Boom-Mast, MC310C	Alum. 1
EC1	TUBE CLAMP	Element	Alum. 8
F1	BALUN ASSY.	Driven CB-2F/2	1
F2	SADDLE	Driven 25D	Alum. 4
F3	STUB ROD	Driven 5 - 850	Alum. 1
F4	INSULATOR	Driven	P.P. 2
F5	INSULATOR	Driven $\phi 32 \times 210$	P.C. 1
S1	SCREW	Element D4 x 10 W.	Sus. 8
S2	SCREW	Driven M4 x 15 W. N.	Sus. 6
S3	SCREW	Element M4 x 30 W. N.	6
S4	SCREW	Boom M8 x 65 W. N.	Galv. 4
U1	U-BOLT	Element C1, 2 M - 20A W. N.	Galv. 6
U3	U-BOLT	Element C3 M - 40A W. N.	Galv. 4
U4	U-BOLT	Element C1, 3, 4 M6 - 32A W. N.	Galv. 8
U5	U-BOLT	Element C2 M8 - 40A W. N.	Galv. 4
U6	U-BOLT	Boom-Mast M8 - 50A W. N.	Galv. 2

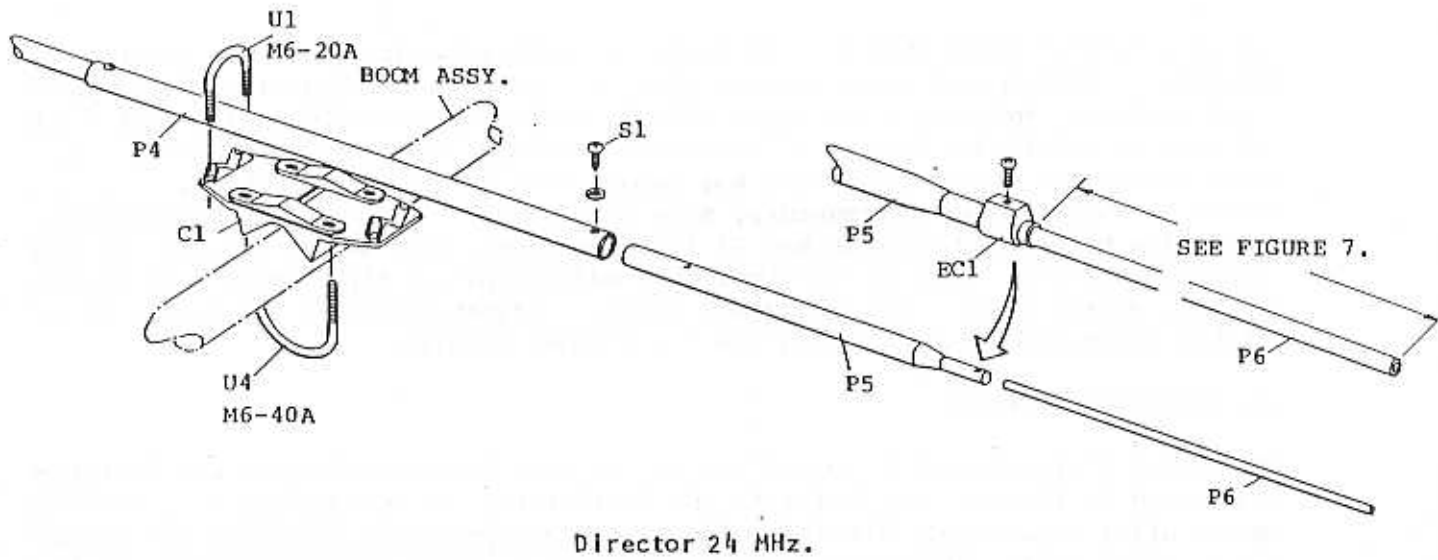

Director 24 MHz.

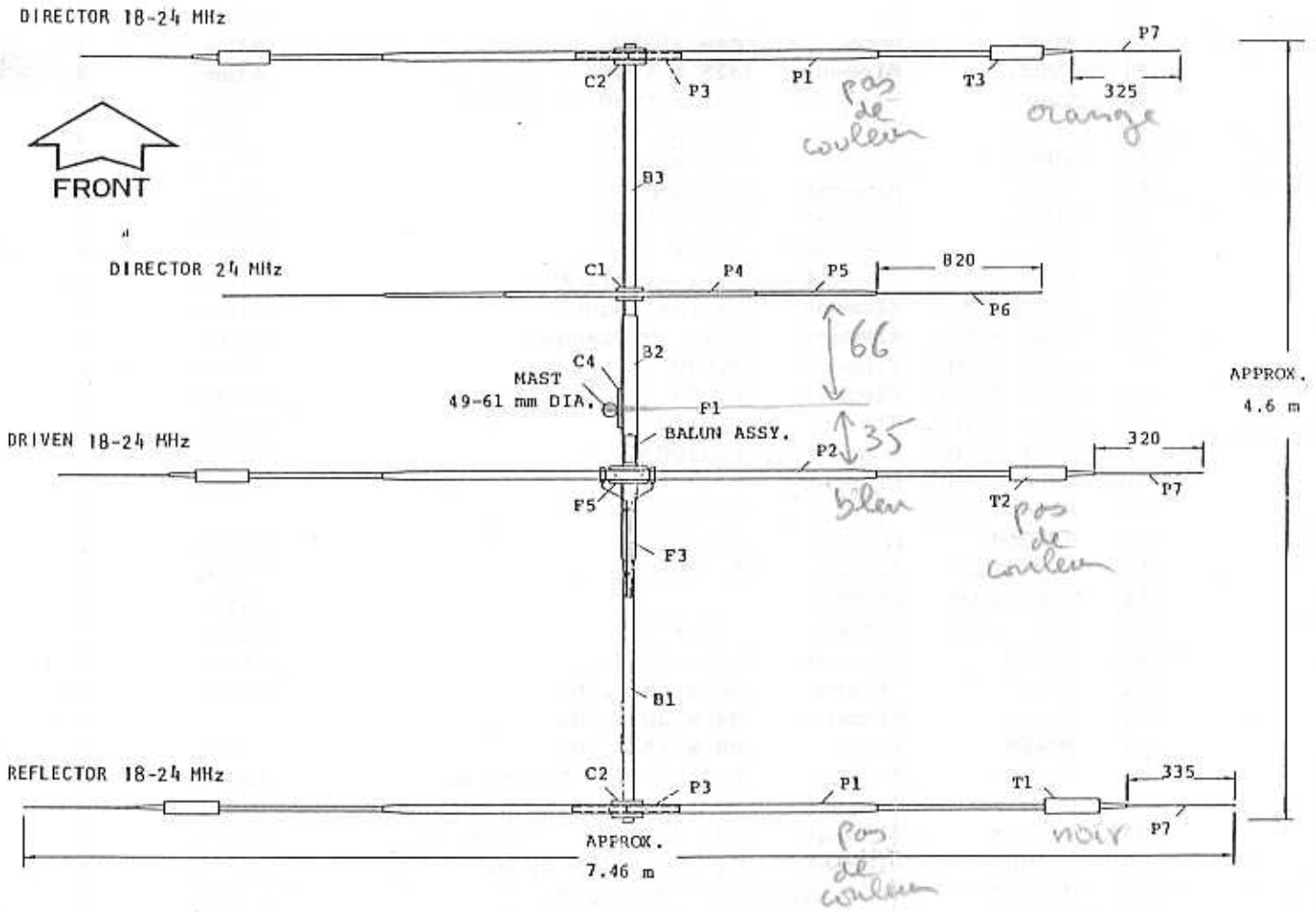

Figure 7. Model 248A, Overall Top View. 1989-7 above.